



USER'S MANUAL FOR THE PACKING AND USE

PILOT EMERGENCY SEAT PARACHUTE SYSTEM PTCH-P40

Issue No.: 2
Date of issue 1.6.2008

CONTENTS:

Contents.....	2
1. Objective, technical specifications, function description.....	3
2. Technical parameters.....	3
3. Technical documentation requirements.....	5
4. Ordering information.....	5
5. Instructions for use.....	6
6. Maintenance instructions.....	6
7. Repair instructions.....	7
8. Storage instructions.....	7
9. Transport instructions.....	8
10. Packing instructions for the parachute PTCH-P40.....	9
11. Packing tools.....	13
12. Pre-packing set-up and packing.....	14
13. Pre-flight preparation.....	34

1. Objective, technical specifications, function description

1.1 Objective

- 1.1.1. Herein described parachute system PTCH-P40 (further described as the parachute) can be utilized to save the pilot's life in aircraft types where seat type emergency parachute systems are or may be used.

1.2 Technical specifications

The parachute comprises of the following parts:

- 1.2.1 Canopy V-066
The main part of the drag inducing area that provides safe descent and landing.
- 1.2.2 Harness PS-040
Attaches and fixes the parachute to the pilot's body, distributes and hence reduces dynamic loading caused by the opening shock.
- 1.2.3 Back padding P-019
Provides the comfortable rest in the aircraft pilot seat.
- 1.2.4 Pilot chute PV-027
Extracts the canopy with the suspension lines from the container.
- 1.2.5 Seat cushion SP-015
Provides the comfortable seat position.
- 1.2.6 Bridle SS-065
Connect the pilot chute to the canopy.
- 1.2.7 Container OP-051
Contains the canopy and suspension lines while in a packed state.
- 1.2.8 Ripcord U-040
Designed for hand deployment of the canopy.
- 1.2.9 Carrying bag G-206
Holds the parachute during transport and storage.

1.3 Function description

- 1.3.1 After bailing out of the aircraft the pilot pulls the ripcord out of its pocket on the harness. This withdraws the ripcord pin and releases the pilot chute.
- 1.3.2 The pilot chute inflates and by the bridle extracts the canopy with the suspension lines. The suspension lines are unstowed and free the diaper.
- 1.3.3 The canopy fills with air and slows down the fall.
- 1.3.4 Flight direction of the canopy is controlled by pulling down the steering lines.

2. Technical parameters

2.1 Technical data

- | | |
|---|--------------------|
| 2.1.1 Pilot chute area | 0,7 m ² |
| 2.1.2 Canopy area | 44 m ² |
| 2.1.3 Maximum weight of the parachute without the carrying bag and seat cushion | 8,6 kg |
| 2.1.4 Maximum weight limit (pilot with the parachute) | 115 kg |
| 2.1.5 Minimal weight limit (pilot with the parachute) | 57 kg |

- | | | |
|--------|---|-----------------------|
| 2.1.6 | Descent rate with suspended 85 kg | 4,8 m.s ⁻¹ |
| 2.1.7 | 360 ⁰ turn around time | 8 s |
| 2.1.8 | Dimensions of the packed parachute without the seat cushion | 250 x 390 x 120 mm |
| 2.1.9 | The reliable parachute functioning is guaranteed on condition of an immediate opening after the bail out or also after a longer freefall with holding time. | |
| 2.1.10 | The minimum height for bailing out is set to 90 m at minimum speed of 100 km.h ⁻¹ on condition that the opening is immediate after the bail out (the pilot's body position must be stabilized during opening of the parachute!). Providing these conditions the canopy is fully inflated 4 seconds before landing. | |
| 2.1.11 | The use of the parachute (its opening) is limited to the speed of 278 km.h ⁻¹ (150 kt) | |

2.2 Operation conditions

- 2.2.1 The thermal resistance of the canopy has been proven in the range -40°C to 93,3°C.
- 2.2.2 The re-pack cycle is 6 months.
(determining date is the day in a month).

2.3 Vital reliability parameters

- 2.3.1 Service life – Reliable function of the parachute is guaranteed for the period of 10 years providing the prescribed conditions for storage, periodical inspections, airing, use and repairs are met. The service life is measured from the date of manufacture (month and year) stamped in the parachute packing card. The service life may be extended after an inspection at the manufacturer. Tests of mechanical and physical properties of the parachute will be carried out and according to their results the service life may be prolonged, with an extension of maximum two years. If the parachute requires a repair, it will be done only after receiving the parachute owner's agreement with the manufacturer stating the extension of the service life after the repair in the parachute packing card. The parachute must be delivered for a service life extension before the end of the original service life period. The manufacturer states the extension period in the packing card of the parachute. The service life may be prolonged repeatedly after repeated tests of mechanical and physical properties of the parachute fabrics, with the maximum total service life of 15 years.
- 2.3.2 Warranty – The warranty period is 24 months starting from the date of manufacture indicated in the parachute packing card. The warranty is valid only providing these conditions:
- the manufacturer's instructions for transport and storage are adhered to.
 - the parachute is properly checked, aired and re-packed every 6 months
(determining date is the day in a month)
 - the parachute packing card is properly maintained.
 - damaged or excessively worn parts are repaired or replaced timely.
- The warranty is not valid for the parachutes where:
- the packing card has been lost.
 - the packing card does not accompany the parachute.
 - the packing card is not properly maintained;
 - the manufacturer's instructions for storage and transport have not been adhered to.

- the parachute has been mechanically damaged by an incorrect use.
- the parachute has been handled in ways other than described in the Owner's manual for the packing and use.

- 2.3.3 Warranty after repair – Warranty after a repair carried out by the manufacturer is 24 months starting from the date of repair indicated in the parachute packing card. Warranty after repair is only applicable to the parachute parts that were repaired. If warranty after repair exceeds the end of the service life it is valid until the end of the service life only. Warranty after repair is valid providing the conditions indicated in the paragraph 2.3.2. are strictly adhered to.
- 2.3.4 Warranty after extension of service life – Warranty after extension of service life is not offered.

3. Technical documentation requirements

3.1 Technical documentation requirements are:

- Parachute packing card

4. Ordering information

4.1 Information needed while ordering a parachute system:

- parachute type
- number of units
- name and address for individual clients
- company name and address for corporate clients

4.2 Information needed while ordering parachute parts:

- parachute type with its serial number and packing card
- part name and type
- number of pieces

4.3 Component list

4.3.1 The parachute comprises of the following parts:

- Canopy V-066
- Harness PS-040
- Back padding P-019
- Pilot chute PV-027
- Seat cushion SP-015
- Attachment bridle SS-065
- Container OP-051
- Ripcord U-040
- Carrying bag G-206

4.3.2 Packing tools delivered together with the parachute (PVC bag , p. n. 3611):

- finger trapped pilot chute closing cord 1 pc closing cord, p. n. 2112
closing cord washer, p.n. 3599
- temporary tie to attach the pull-up cord
to the pilot chute closing loop 1 pc closing cord, p.n. 2112

- temporary pin with red warning cord	2 pcs	PAD cord - red, p.n. 2113 temporary pin, p.n. 3610
- pull-up cord with washer	1 pc	PAD cord - red, p.n. 2113 washer, p.n. 3612
- temporary locking loop with washer	2 pcs	PAD cord - khaki, p.n. 2115 washer, p.n. 3612
- pull-up cord	2 pcs	PAD cord - khaki, p.n. 2115
- rubber band - ø 4 cm	8 pcs	p.n. 3001
- rubber band 2"x3/8"x1/16"	3 pcs	p.n. 3218

4.3.3 Parachute is supplied with the following items:

- Parachute packing card
- User's manual for the packing and use

5. Instructions for use

5.1.1 Limitations - in accordance with the paragraphs 2.1 and 2.2 of the User's manual for the packing and use.

5.2 Standard use

5.2.1 The parachute is checked and packed as described in the User's manual for the packing and use.

5.2.2 After leaving the aircraft the pilot opens the parachute by pulling the ripcord out of ripcord pocket on the harness. Once the canopy is inflated, the pilot controls the flight. The parachute is controlled by the left and right steering line handle. The parachute rotates around its axis to the right when the right handle is pulled down and rotates around its axis to the left when the left handle is pulled. Before landing the pilot turns the parachute against the wind and releases the steering line handles. Push your legs together during landing.

6. Maintenance instructions

6.1 Before packing

- Before packing the parachute for jump the parachute completeness and technical condition must be checked.
- The pre-pack inspection must be done according to the instructions specified in the User's manual for the packing and use.
- Particular attention must be paid to the parts that are crucial for the parachute correct function. These parts are:
 - canopy V-066 together with the suspension lines
 - pilot chute PV-027
 - bridle SS-065
 - ripcord U-040, particularly the ripcord pin
 - harness PS-040, harness hardware, snap and link connectors
- Pre-pack inspection results must be noted in the parachute packing card.
- Damaged replaceable parts must be replaced.

- Replacement of any part of the parachute must be noted in the parachute packing card.

6.2 Replacement of damaged parts

User is entitled to replace the following parts:

- pilot chute PV-027;
- bridle SS-065;
- seat cushion SP-015;
- ripcord U-040;
- carrying bag G-206;

Individual parts must be replaced according to the instructions given by the User's manual for the packing and use.

6.3 Crucial parachute parts:

- canopy V-066 together with the suspension and steering lines
- pilot chute PV-027;
- bridle SS-065;
- ripcord U-040, particularly the ripcord pin
- harness PS-040, harness hardware, snap and link connectors

Only a packer or the manufacturer are entitled to assess condition of the above parts and decide about their replacement.

7. Repair instructions

The parachute can be repaired. Repairs are done by the manufacturer only.

8. Storage instructions

8.1 Before storage the parachutes must be inspected, repaired or any damaged parts replaced. The parachutes must be stored on shelves in a dry, dark, well ventilated room. Height of the bottom shelf must be at least 0,1 m as measured from the floor. The distance between the shelf and any adjacent wall must be at least 0,5 m and between the shelf and any heating element at least 1 m. Parachutes must be stored in maximum two layers. It is not allowed to store any iron objects other than parachute parts, oils, easily inflammable fluids, acids, or substances liberating active gases in the room where the parachutes are deposited.

8.2 If the parachute is stored for a longer period of time it must be aired for 24 hours every 6 months. Airing must be done in the shade and at a place with no direct sunshine. Airing must be noted in the parachute packing card.

8.3 The following conditions must be kept in the storage room:

- Temperature during the day	+14 až + 25 ⁰ C
- Relative humidity during the day	35 až 73 %
- Annual average relative humidity	45 až 55 %

8.4 If the above conditions are not adhered to the parachute must be sent to the manufacturer to assess the mechanical and physical properties of the parachute.

9. Transport instructions

9.1 Transport and storage instructions - packed parachute

The parachute is stored and transported in the carrying bag packed according to the instructions described in the User's manual for the packing and use.

9.2 Transport and storage instructions - open parachute

If an opened parachute is to be stored and transported in the carrying bag, it must be packed in the bag according to this procedure:

- Pleat the canopy and chain-loop the suspension lines. Position the pilot chute on the apex of the canopy and roll the canopy toward its bottom skirt. Insert the container, harness and rolled canopy with the lines in the carrying bag.
- Close the bag zipper and seal the slider.

10. Packing instructions for the parachute PTCH-P40

10.1 General instructions

Pre-pack inspection, damaged parts replacement, pre-pack set-up and packing can be done only by a packed certified by the manufacturer.

Before packing the parachute must be checked thoroughly for completeness and any damage. Damaged parts must be repaired or replaced in accordance with the parachute technical drawings and specifications. It is not allowed to use the parachute with damaged or otherwise non-airworthy parts and materials. During packing it is not recommended to expose the parachute to direct sunshine.

10.2 Parachute pre-pack inspection:

10.2.1 Canopy and suspension lines (V-066) inspection

Spread the canopy along a packing table. Check the fabric, binding tapes and stitching for any damage and the fabric for stains. After inspection use the bridle SS-065 to attach the canopy to the fixing point of the packing table.

Fig. A

Fig. A



Straighten the canopy along its whole length and inspect the suspension lines. Straighten the lines and inspect them thoroughly from the skirt of the canopy to the SL-01 link connectors. Inspect the lines from all sides

Fig. B

Fig. B



The suspension lines must not be damaged, worn, or otherwise impaired.

Ensure that all screws of the connector links are properly tightened.

The screws must be tightened all the way using a wrench. It should not be possible to open the screws with your fingers.

Further inspect bartacks of the suspension lines together with the 2"x3/8"x1/16" rubber bands holding in place the end loops of the lines. The rubber bands must not be damaged.

Fig. C

Fig. C



10.2.2 Inspection of harness PS-040

During harness inspection, check for any damaged webbing and stitching. Further, check condition and functionality of harness hardware. Fig. D

Fig. D



10.2.3 Inspection of container OP-051

During inspection of container check for any damaged fabric, binding tape, reinforcement or grommet.

10.2.4 Inspection of the seat cushion SP-015 and back padding P-019

During inspection of seat and back padding check for any damage of fabric, zippers and stitching.

10.2.5 Inspection of ripcord U-040

Inspect the ripcord for any damage of the cable or bends of the pin. Also carefully look for any signs of the termination ball or pin becoming loose on the cable.

10.2.6 Inspection of the bridle SS-065

Check for any damage of stitching of the end loops. Fig. E

Fig. E



10.2.7 Inspection of the pilot chute PV-027

During inspection of the pilot chute inspect the pilot chute canopy fabric, stitching, and condition of the spring. Also look for sharp edges on the grommets stabilizing the pilot chute on the closing loop. Fig. E.

10.2.8 Inspection of the carrying bag G-206

During inspection of the carrying bag inspect bag fabric and binding tapes for any damage or dirt.

10.3 Replacement of damaged parts

10.3.1 Bridle SS-065

Replace the bridle according to figures F, G, and H.

Fig. F

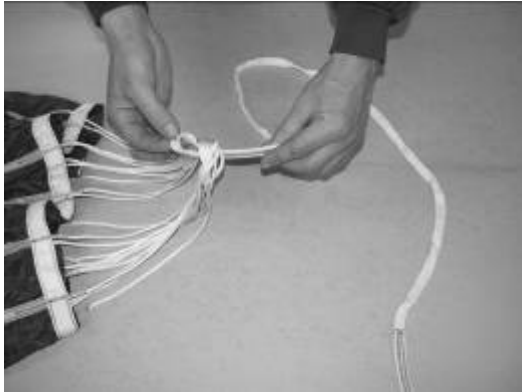
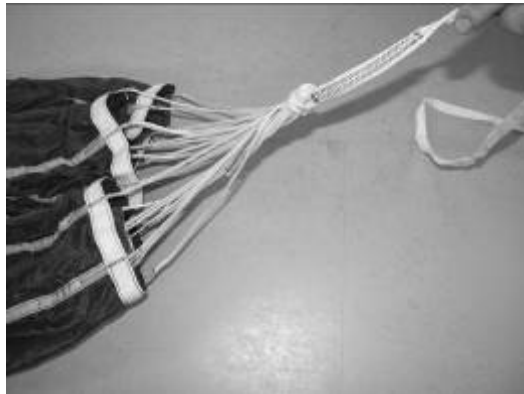

Fig. G



Fig. H



10.3.2 Pilot chute PV-027

Replace the pilot chute according to figures I, J, and K.

Fig. I



Fig. J

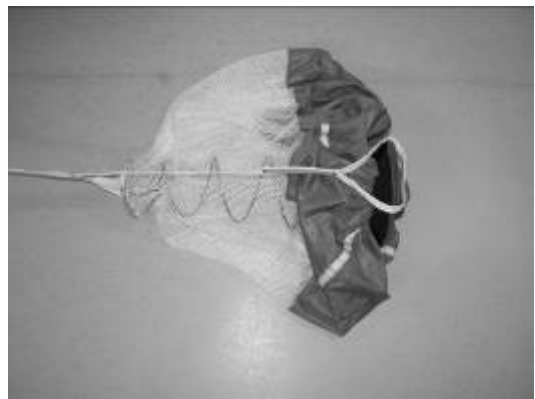

Fig. K



10.3.3 Seat cushion SP-015

Fig. L

Open the parachute container zipper (4), remove the seat cushion (1) and withdraw both leg straps (3). Connect the seat cushion (2) to the parachute container with the zipper and thread back the leg straps.

Check the leg straps. They must not be twisted!

Fig. L



10.3.4 Ripcord U-040

Replace a damaged ripcord with a new one.

10.3.5 Carrying bag G-206

Replace a damaged carrying bag with a new one.

11. Packing tools

Temporary locking loop - 2 pcs.
Cutting length 200 mm
Loop length 55 to 60 mm
(with the knot tightened)
material: PAD cord - khaki, p.n. 2115



Temporary locking loop
with washer - 2 pcs
material: washer, p.n. 3612



Temporary pin with red warning cord
- 2 pcs.
Cord length (from the pin to knot)
500 mm.
material: PAD cord - red, p.n. 2113
temporary pin, p.n. 3610

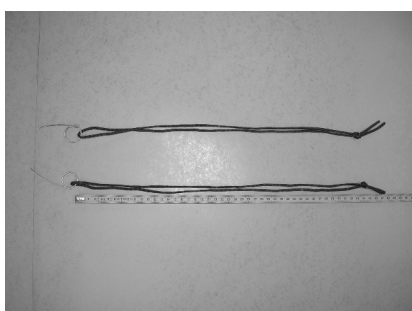

Pull-up cord - 2 pcs
Length 1050 mm
material: PAD cord - khaki,
p.n. 2115



Pull-up cord with washer - 1 pc
Cutting length 1300 mm
Length up to the knot 600 mm
material: PAD cord - red,
p.n. 2113
washer, p.n. 3612

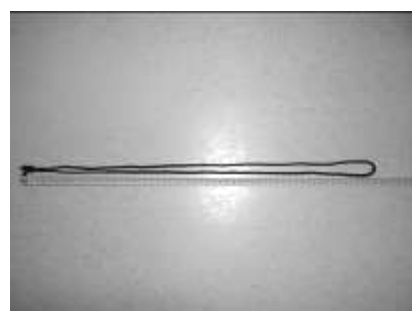

Temporary tie to attach the pull-up
to the pilot chute closing loop -1 pc
Length 200 mm.
material: closing cord, p.n. 2112



Packing weight - 6 pcs

Green safety tie, tensile strength 4,5 - 7,5 N to seal the ripcord pin and pilot chute closing loop

Pilot chute closing cord - 1 pc
Cutting length 1450 mm.
material: closing cord,p.n. 2112



Pilot chute closing cord washer - 1 pc,
p.n. 3599
Finger trapping needle - 1 pc

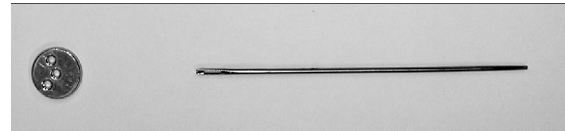

12. Pre-packing set-up and packing

12.1 Pre-packing set-up

12.1.1 Stretch the canopy out on the packing table.
Attach the bridle SS-065 to the end of the table (Fig.M). Separate the suspension lines into two groups (Fig. N), so that lines no. 1 to 12 are on the right side and lines 13 to 24 on the left side. The name plate gore should be the in the middle and on top.

Fig. M



Fig. N



12.1.2 Do the suspension lines check (Fig. O and P).

Fig.O

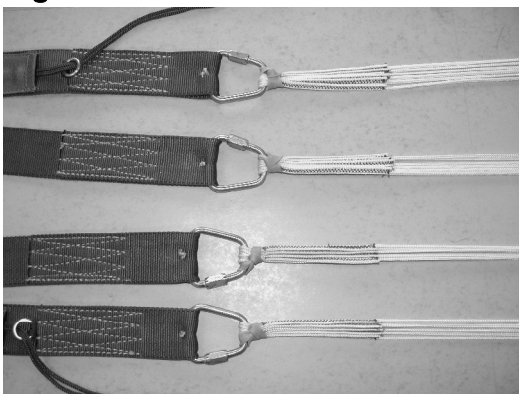

Fig.P



- 12.1.3 Thread the ripcord cable into its flexible housing. Insert the ripcord handle in the pocket on the harness (Fig. R).

Fig. R



- 12.1.4 Lay out the harness with the container and back padding on the packing table as pictured in Fig. S and open the flaps (Fig. T).

Fig. S



Fig. T



12.2 Parachute packing

Place line no.13 (with the diaper) in the middle of the packing table (Fig.1), place line no. 14 on top of line no. 13 and continue in the same manner up to line no. 24 (Fig.2 and 2a). Pull out the individual gores.

Fig. 1



Fig. 2



Fig. 2a



Secure the left half of the canopy with the weights (Fig.3) a flip the right side group of gores over the left (Fig.4).

Fig. 3



Fig. 4



Place line no.12 in the middle of the packing table (Fig.5), place line no.11 on top of line no.12 and continue in the same manner down to line no. 1 (Fig.6, 6a).

Fig. 5



Fig.6

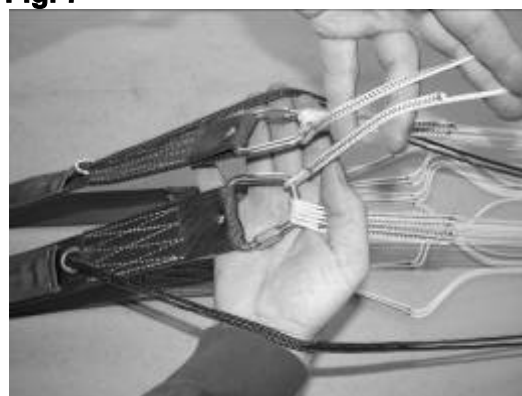

Fig. 6a



Fig. 7

After pleating the canopy, check the suspension lines. Lift the upper risers with your right hand and separate the inner lines no.1 and 24 with the left hand (Fig.7). Slide your hands along the lines to the bottom of the canopy. There must be two distinct vertical halves (upper and lower) on the pleated canopy and the inner lines in your left hand must be lines marked no.1 and no. 24.



Fold the skirt up 90 degrees parallel to the radial seams (Fig.8). Long fold both sides of the canopy to meet at the center. Secure with the weights (Fig.9).

Fig.8



Fig.9



Long fold both sides to meet at the center again. Then, do the long fold again (Fig.11)

Fig.10



Fig.11



Secure the diaper by stowing the suspension lines (Fig.12, 13, 14, 15, 16).

Fig.12



Fig.13



Fig.14

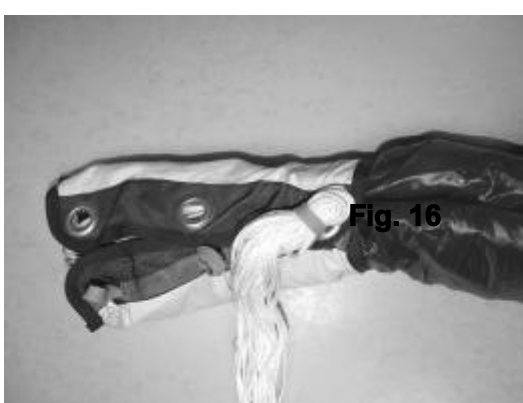

Fig.15



Fig. 16

Fig.16



Move the harness together with the container and back padding towards the canopy (Fig 17). Route the risers as in Fig.18.

Fig.17



Fig.18



Cover the risers with the side flaps (Fig.19). Apply tension to the flaps and straighten the risers (Fig.20).

Fig.19



Fig. 20



Flip the container as in Fig 21. Position the link connectors to the container sides as in Fig.22.

Fig. 21



Fig. 22



Route the suspension lines towards the center of the container (Fig. 23). Stow the lines through the rubber bands as depicted in Fig. 24, 25, 26, 27, and 28.

Fig. 23



Fig. 24



Fig. 25



Fig. 26



Fig. 27



Fig. 28



Leave space between the line stows in the middle of the container (Fig. 29, 30).

Fig. 29



Fig. 30



Continue packing (Fig. 31). The last line stow should be oriented as in Fig. 31. Place the canopy with the secured diaper in the left side of the container (Fig. 32).

Fig. 31



Fig. 32



Insert the temporary locking loops with washers in the outer grommets in the bottom of the container and a pull-up cord in the middle grommet (Fig. 33, 33a, 33b).

Fig. 33



Fig. 33a (from below)



Fig. 33b



Place pull-up cords in the both temporary locking loops, Fig. 34, 34a.

Fig. 34



Fig. 34a



Position the pull-ups as in the Fig. 35.

Fig. 35



S-fold the canopy in the container (Fig. 36).

Fig. 36



Now, we prepare one container side for closing. Cover the riser with the side closing flap and secure the flap by tucking the flap tab with velcro tape into the slit in the bottom of the container (also with velcro) (Fig. 37). Fig. 38 depicts the resulting shape of the container side.

Fig. 37



Fig. 38



S-fold the bottom (bigger) half of the canopy in the prepared side of the container (Fig. 39 and 39a).

Fig. 39



Fig. 39a



Make sufficient room for the pull-up cord and temporary locking loops around the grommets in the bottom of the container (Fig. 40). Pass the pull-up as well as the temporary locking loops through the grommets in the upper flap of the container and using the pull-ups and temporary pins (Fig. 41) secure the half of the container (Fig. 42).

Fig. 40



Fig. 41

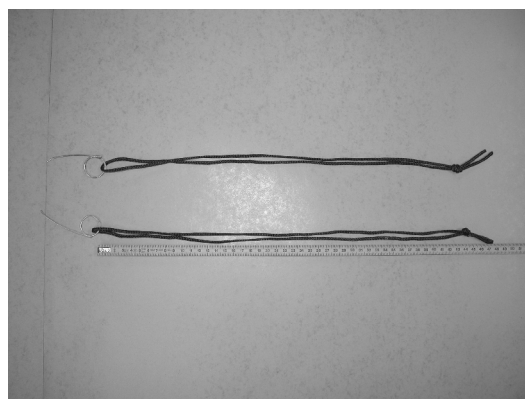

Fig. 42



Place the remaining half of the canopy in the opposite side of the container according to the Fig. 43 and 44.

Fig. 43



Fig. 44

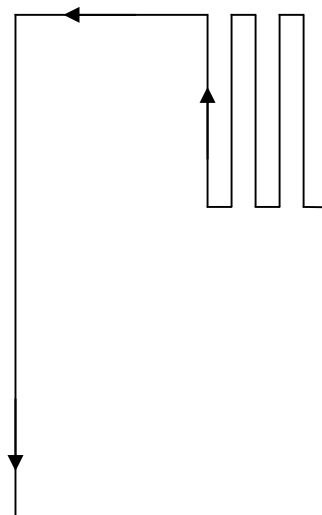

Continue folding the canopy from the side of the container to the center according to Fig. 45 and 46.

Fig. 45



Fig. 46

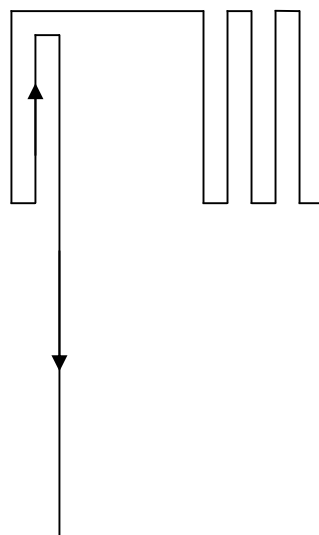

Now, we prepare the other container side for closing. Cover the riser with the side closing flap and secure the flap by tucking the flap tab with velcro tape into the slit in the bottom of the container (also with velcro) (Fig. 47, 47a).

Fig. 47



Fig. 47a



Continue folding the canopy according to Fig. 48 and 49.

Fig. 48



Fig. 49

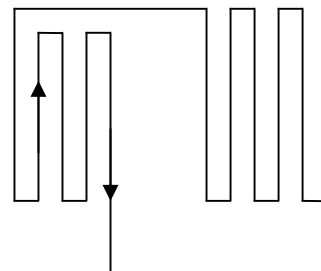

Push the apex vent and the vent lines together with a part of the bridle between the folded canopy and the side flap (Fig. 50, 50a, 51).

Fig. 50



Fig. 50a



Fig. 51

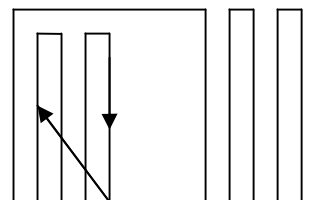

Pass the pull-ups as well as temporary locking loops through the grommets in the upper flap of the container (Fig. 52). Press the folded and packed canopy to create space in the center part of the container (Fig. 53).

Fig. 52



Fig. 53



Now, we close the remaining half of the container. Remove one temporary pin and pull the pull-up so that the temporary locking loop appears. Secure the loop with a temporary pin. Repeat the same with the other temporary locking loop.

Remove the pull-up cords -2 pcs!

Press your hand against the center of the container and form a hole for the pilot chute (Fig. 55).

Fig. 54



Fig. 55



Closing loop scheme (Fig. 56).

Please note that the closing cord, p.n. 2112 (Fig. 56, item 18) and washer, p.n. 3599 (Fig. 56, item 19) must be approved by the manufacturer. Use of any other cord is prohibited!

Fig. 56

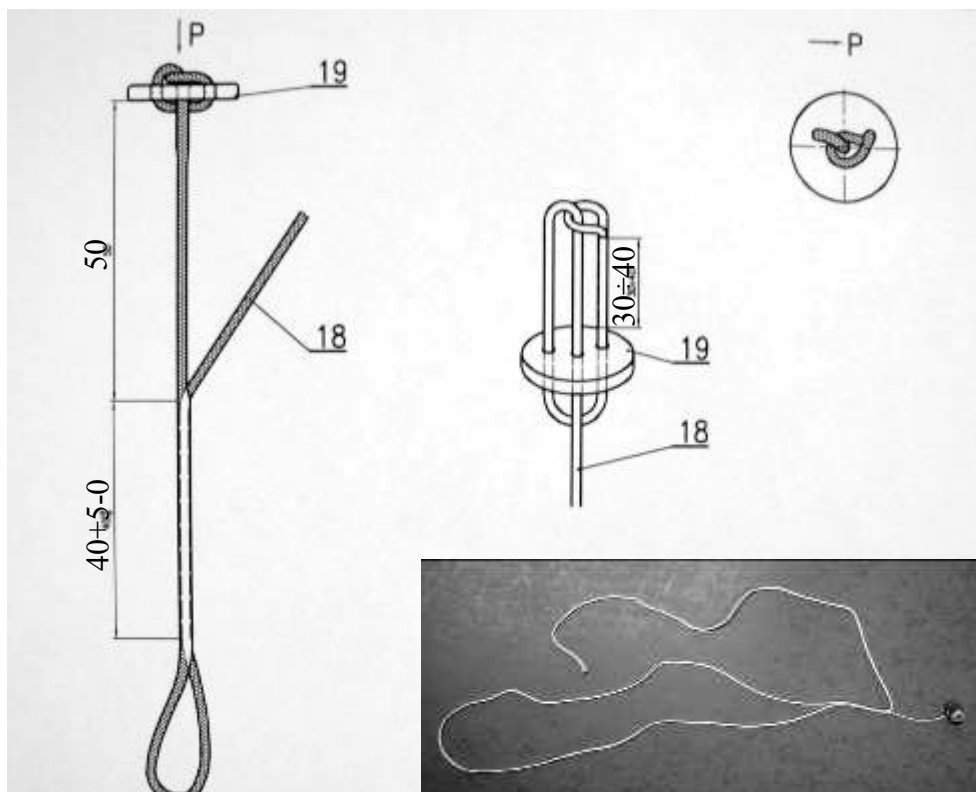

Pass the pull-up cord through the grommet in the lower flap. S-fold the bridle at the base of the upper flap (Fig. 57). Pass the pull-up through the grommet in the upper flap. Use your hand to press the flaps together, so that the grommets meet (Fig. 58).

Fig. 57



Fig. 58



Lead the closing cord through the bottom opening of the pilot chute and into the grommet that is closer to the rim of the pilot chute (Fig. 59). Pass the end loop of the closing cord through the middle grommet (Fig. 60) and lead it towards the end loop of the bridle (Fig. 61).

The closing cord must be routed through the middle of the pilot chute spring and should not be twisted!

Use the temporary tie to attach the closing cord to a pull-up.

Make sure that after tightening the tie there should be a 20 mm gap between the closing cord and pull-up.

Fig. 59



Fig. 60



Fig. 61



Fig. 62



Use the attached pull-up to pass the closing cord through the grommets in the container and secure the closing cord with the ripcord pin.

Fig. 63



Fig. 64



Once the closing cord is secured, cut the temporary tie (Fig. 65).

Remove the tie!

Do not damage the closing cord! If it is damaged it must be replaced!

The ripcord pin must be inserted in such a way that a spontaneous release of the ripcord out of the closing line loop is avoided. The pin cannot be inserted too much, either. The proper pin insertion is shown in fig. 66 and 66a.

Fig. 65



Fig. 66



Fig. 66a

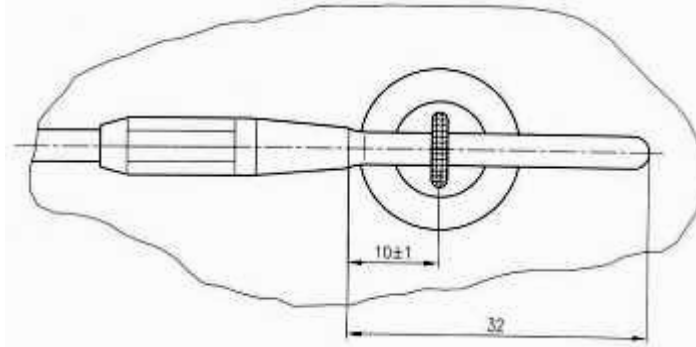

Position the pilot chute on the container so that the pilot chute spring sits in the hole prepared in one of the previous steps (Fig. 55). Make sure that the spring is exactly in the center of the container (Fig. 67). Tie the closing cord around a wooden packing stick. Press the top of the pilot chute (Fig. 68) and at the same time pull the closing cord. Secure the compressed pilot chute approx. 60 mm from the top of the container (Fig. 69).

Fig. 67



Fig. 68

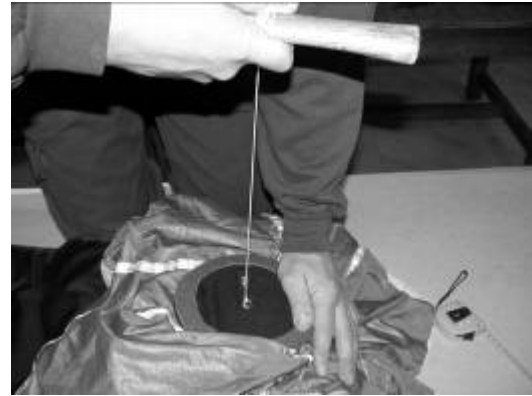

Fig. 69



Remove the temporary pins - 2 pcs.

Remove the temporary pins very carefully to avoid any damage to the pilot chute fabric.

Turn the rubber rim of the pilot chute upwards and spread out the pilot chute (Fig. 70). Remove the temporary locking loops from the grommets (2 pcs) and check the position of the ripcord pin (Fig.71).

Fig. 70



Fig. 71



Tuck the pilot chute fabric under the pilot chute (Fig. 72). Turn the rubber rim back down (Fig. 73).

Fig. 72



Fig. 73



Use both knees to press the pilot chute against the container. Pull the closing cord and secure the pilot chute in the fully compressed position (Fig. 74).

Use adequate force to avoid any damage to the closing cord. If the cord is damaged it must be replaced.

Shape the container. Make a safety knot close to the middle grommet of the pilot chute (Fig. 75, 75a). Cut the closing cord approx. 10 mm above the knot. Dress the pilot chute (Fig. 76).

Fig. 74



Fig. 75



Fig. 75a

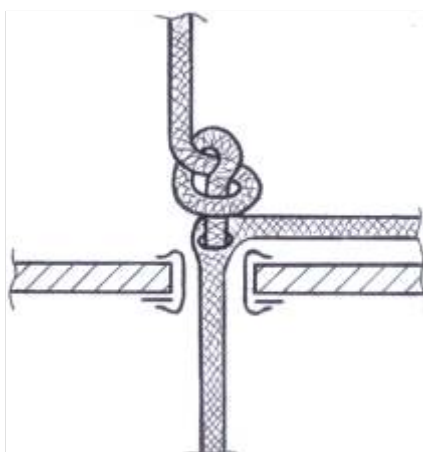

Fig. 76



Check the proper position of the ripcord pin and make sure that all temporary closing loops have been removed. Inspect the closing cord for any signs of damage.

Seal the container with the green safety tie of tensile strength of 4,5 - 7,5 N (Fig. 77). Cover both ends of the tie with a paper tape containing the date of packing, name of packer and his signature.

Fig. 77

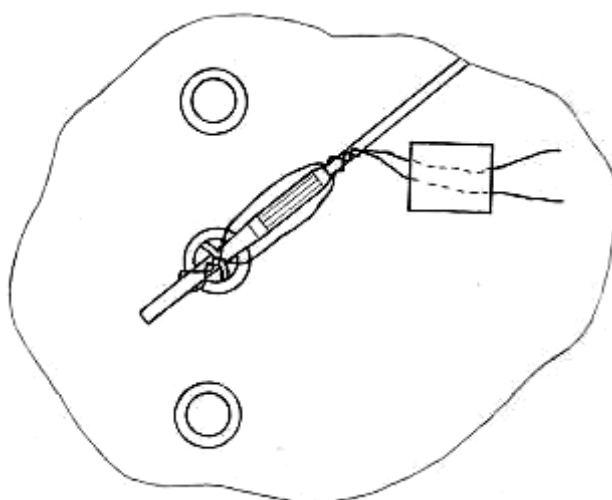

Attach the seat cushion to the container with the zipper (Fig. 78).

Fig. 78



13. Preflight preparation

- 13.1 Before putting on the parachute system check it visually. Make sure that safety tie around the pin is intact and correctly routed. Check the position of the ripcord handle as well as position of the ripcord pin. If any problem is found the parachute must not be used.
- 13.2 During putting on the parachute adjust main back web, leg, and chess straps. Fold and stow the loose webbing ends in the elastic keepers. The harness should not be loose, however at the same time it should not restrict the pilot's movement.